

(Hanging 2 road bikes image in K-style leg)

## Features & Benefits

- Save vast amounts of space by hanging the bicycles vertically from the front wheel.
- Alloy pillar is durable, light weight and rust proof.
- You can choose from two different styles on the base leg layout; K-style for more effective space savings by placing just next to a wall, or X-style for better stability.
- Newly designed alloy clamp holds the attachment securely and easily to adjust height.
- Top hook is padded with soft plastic to prevent damage to the rim. The unique dual hook design avoids twisting the bike while being stored.
- Holds a total of 40 kg (max 20 kg per side).



## Cautions

- **For standard 2-wheel bicycle only. Tandem, recumbent, long tail bike and DH bike with super long suspension fork may not be used on this stand because the rear wheel reach the floor even if you set the top hook at the highest position.**
- **Set the stand on an even and horizontal floor. Adjust each foot precisely to insure each of the foot's four points touch the floor evenly.**
- **Be sure to keep the weight on the stand balanced. A heavy bike on one side without a similar weight bike on the other side may cause the stand to tip.**
- **The clamp is made of strong but lightweight material. Do not overtighten or the bolt may come out of the housing, ruining the clamping mechanism.**
- **Follow the correct order for tightening the screws. Failure to do so may lead to improperly tightened screws.**
- **Screw the bolt using your finger at least in the first 3 – 4 rotations in order to prevent wrong threading. After confirming the bolt is threaded properly without any problem, you can now use a tool for tightening.**
- **To prevent the stand from tipping over backwards, the stand should be placed next to a wall when you choose K-style leg combination.**
- **The rear wheel hook is a guide, not a lock. It is there to help maintain balance.**

## Contact

### MINOURA Japan

(for ALL customers, including Canada)

134-1 Shimomiya, Godo, Anpachi, Gifu 503-2312 Japan

Mail [minoura@minoura.jp](mailto:minoura@minoura.jp)

Web [www.minoura.jp](http://www.minoura.jp)

*If you have question or problem on this product, please contact the shop where you originally purchase this product or the distributor in your country first. The distributor information can be found on our web site. Only when you cannot obtain enough service from them, you can contact Minoura directly.*

### MINOURA North American Tech Center

(for U.S. residents ONLY)

Mon - Fri, 9 am - 5 pm (PCT)

Phone 1-510-538-8599 Fax 1-510-538-5899

Mail [support@minourausa.com](mailto:support@minourausa.com)

Made in Japan

## Part Name

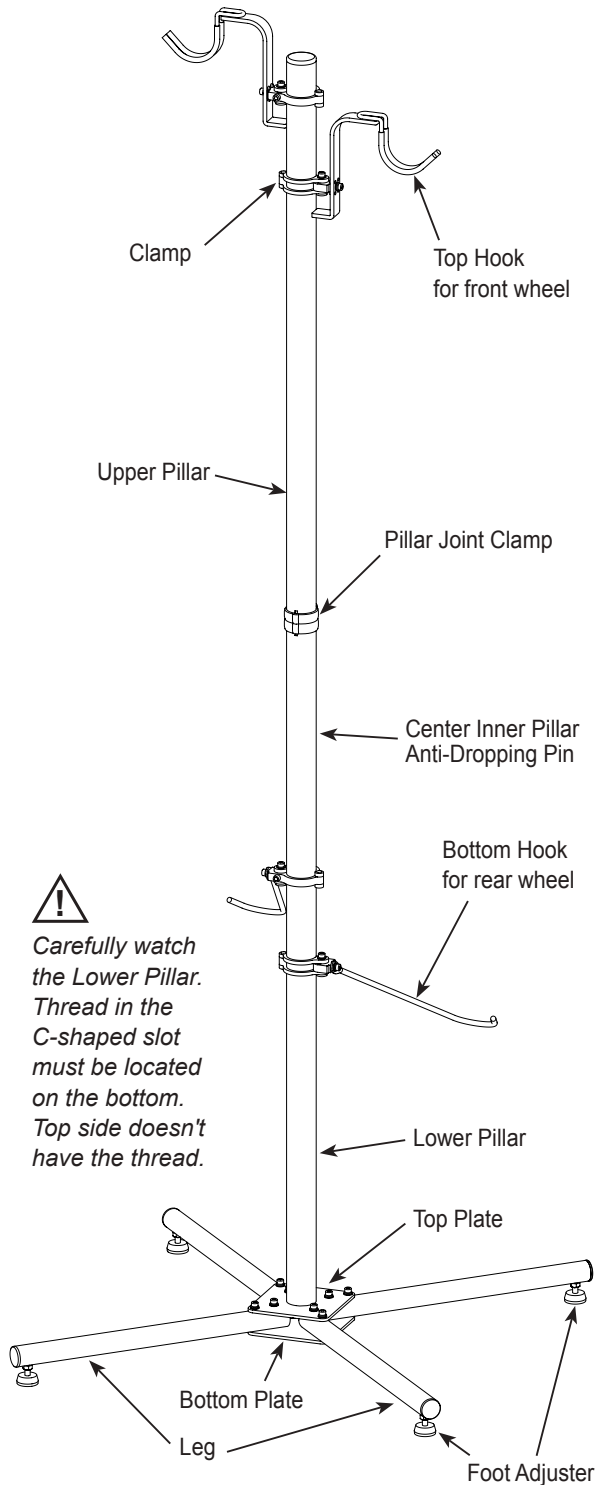

**!**  
Carefully watch the Lower Pillar. Thread in the C-shaped slot must be located on the bottom. Top side doesn't have the thread.

## Required Tools

- 1 x M5 Hex Wrench (included)
- 1 x Phillips Screwdriver (not included)
- 1 x 13mm Spanner (not included)

(We strongly recommend to use the fatter No.3 screwdriver instead of standard No.2)

## How To Read Bolt Size

(Unit: mm)

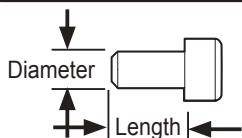

Ex) 6 x 30  
Diameter Length

## Assemble P-600 in K-style Leg

Setting up your P-600 in the K-Style leg configuration saves valuable room because the stand can be placed next to a wall.

- 1** There are two square plates in the kit. Know that while both plates look similar, they are different. The plate for the upper side has larger holes to allow the bolts come through, and there are 4 holes in the center area to be connected with the Lower Pillar. Another plate is for the lower side and the hole sizes are smaller than the upper plate. And also there is no hole in the center area. Make sure the hole layout is not symmetric. The side with in-line 4 holes must face to the back side. (see Fig. A)

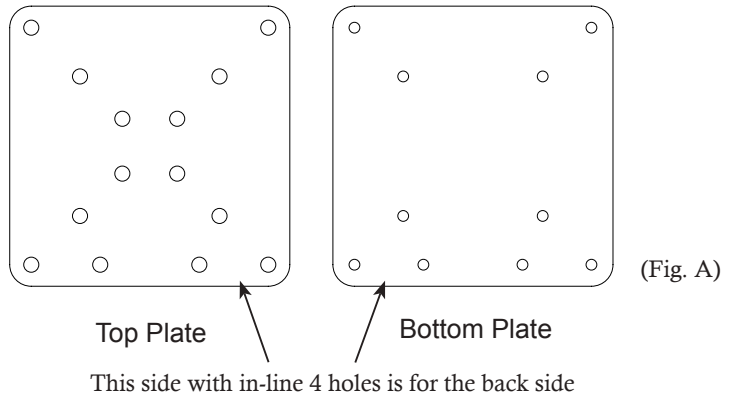

- 2** Confirm the direction of the Lower Pillar. Check the dimension of the pillar shown in Fig. B. If the C-shaped slot is threaded, it is the bottom side (for the side of the legs). If not, it is the upper side. (The top end of the Upper Pillar has a plastic cap)

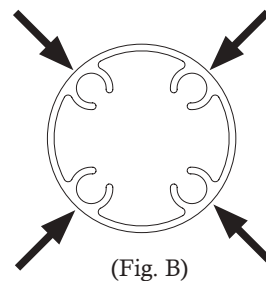

Face the cutout upward. It is hidden under the Pillar Joint Clamp.

- 3** The pillar direction is fixed as the cutout comes to your foreside. Lay down the Lower Pillar as the cutout faces upward, and set the Top Plate as shown in Fig. C.

Screw the M6x30 Bolts to the Lower Pillar through the center hole by the supplied 5mm hex wrench at **4 N.m** torque.

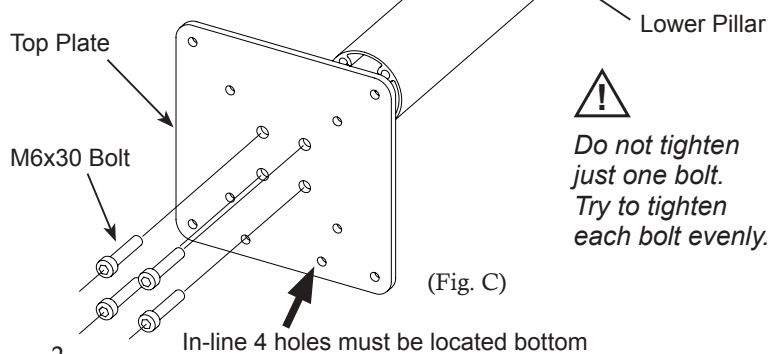

**!**  
Do not tighten just one bolt. Try to tighten each bolt evenly.

In-line 4 holes must be located bottom

## Assemble P-600 in X-style Leg

Setting up the P-600 in the X-style allows the stand to be placed anywhere due to the larger footprint and maximum stability of the X.

It also allows you to install extra optional attachments on the pillar.

Please note, setting the stand up in the X-style does require more floor space.

- 1** There are two square plates in the kit. Know that while both plates look similar, they are different.

The plate for the upper side has larger holes to allow the bolts come through, and there are 4 holes in the center area to be connected with the Lower Pillar.

Another plate is for the lower side and the hole sizes are smaller than the upper plate. And also there is no hole in the center area.

Make sure the hole layout is not symmetric. The side with in-line 4 holes must face to the back side.

(see Fig. G)

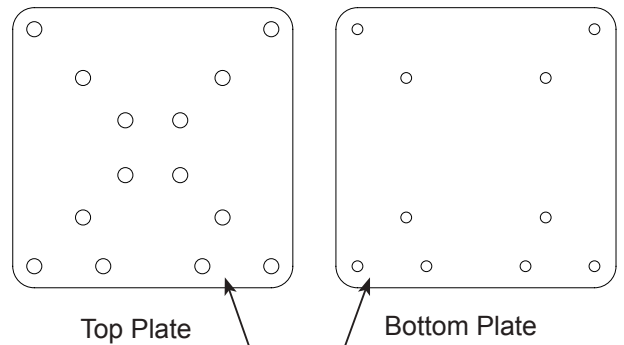

This side with in-line 4 holes is for the back side

(Fig. G)

- 2** Confirm the direction of the Lower Pillar. Check the dimension of the pillar shown in Fig. B. If the C-shaped slot is threaded, it is the bottom side (for the side of the legs). If not, it is the upper side. (The top end of the Upper Pillar has a plastic cap)

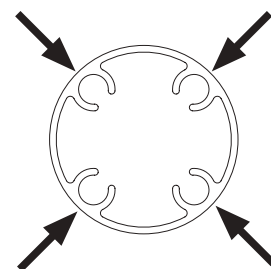

(Fig. H)

- 3** When assembling the Legs in K-shape, the direction of the Lower Pillar is precisely fixed. however, the pillar direction is not fixed at all when assembling in X-shape.

Install the Bottom Plate to the Lower Pillar by screwing M6x30 Bolts to the 4 holes in the center section as shown in Fig. I.

Tighten the bolts by the supplied 5mm hex wrench at **4 N.m** torque.

- 4** Attach the legs to the Lower Pillar. All 4 legs are exactly the same. One end has a reinforcement bracket inside in order to avoid deforming the tube when the bolt is tightened. (see Fig. D)  
Make sure if this bracket is fully inserted into the tube. If it is missing, do NOT use and contact the shop you purchased this product immediately.

**!** If the bracket has been set in wrong position, align the bolt hole on the leg and the bracket.

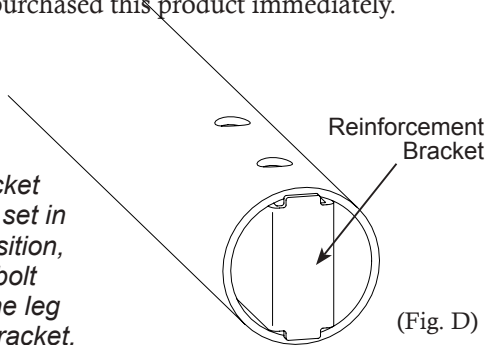

(Fig. D)

- 5** Place the legs in the shape of "K" and sandwich them, Top to Bottom Plates then fix them by 8 M6x50 Bolts. (Use the holes indicated in black dots in Fig. E)  
Put the bolt to the Leg from upper side, and tighten to the thread hole with **6 N.m** torque. (see Fig. F)

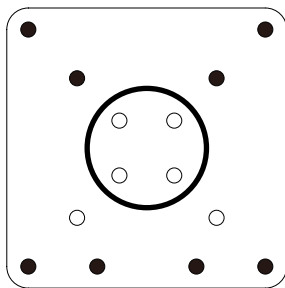

(Fig. E)

**!** Do not tighten just one bolt. Try to tighten each bolt evenly.

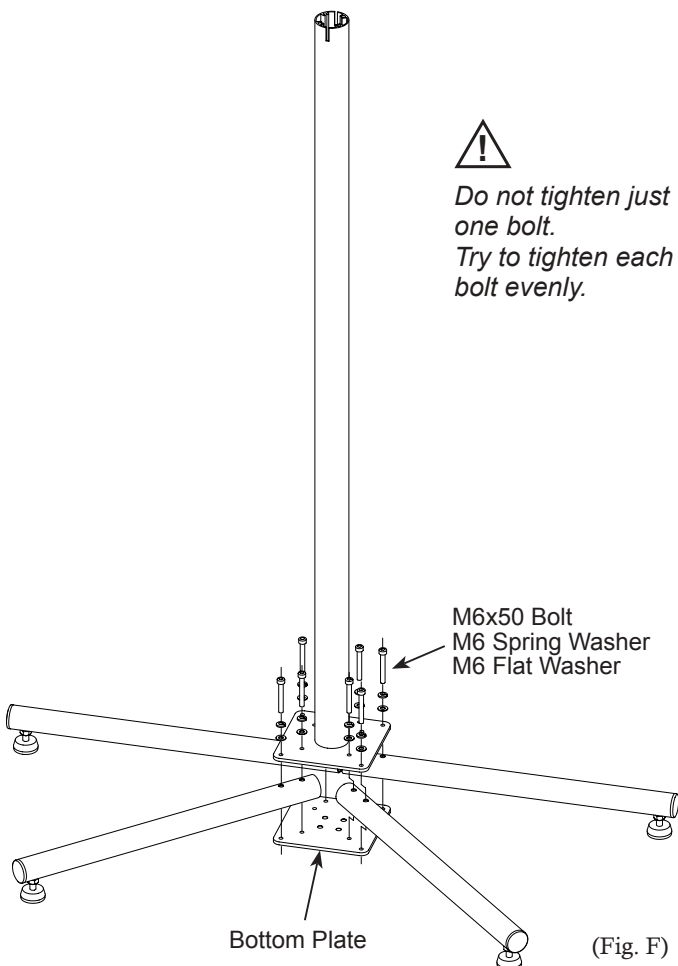

(Fig. F)

The direction of this cutout is not fixed.  
Any directions is OK.

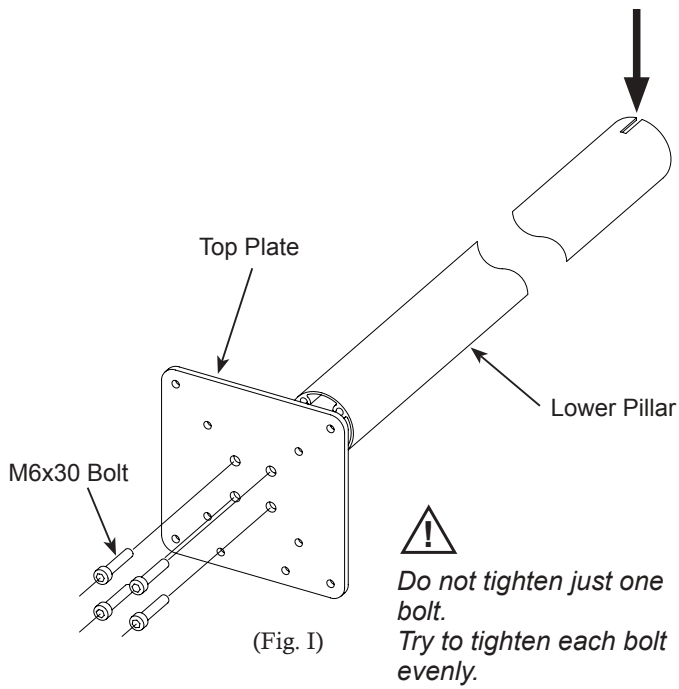

- 4** Install the Legs to the Lower Pillar. All 4 legs are exactly the same. One end has a reinforcement bracket inside in order to avoid deforming the tube problem when the bolt is over tightened. (see Fig. J) Make sure if this bracket is fully inserted into the tube. If it is missing, do NOT use and contact the shop you purchased this product immediately.

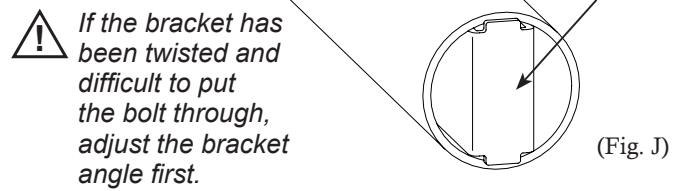

- 5** Place the legs in the shape of "X" and sandwich them by Top and Bottom Plates then fix them by 8 M6x50 Bolts. (Use the holes indicated in black dots in Fig. E) Put the bolt to the Leg from upper side, and tighten to the thread hole with **6 N.m** torque. (see Fig. K)

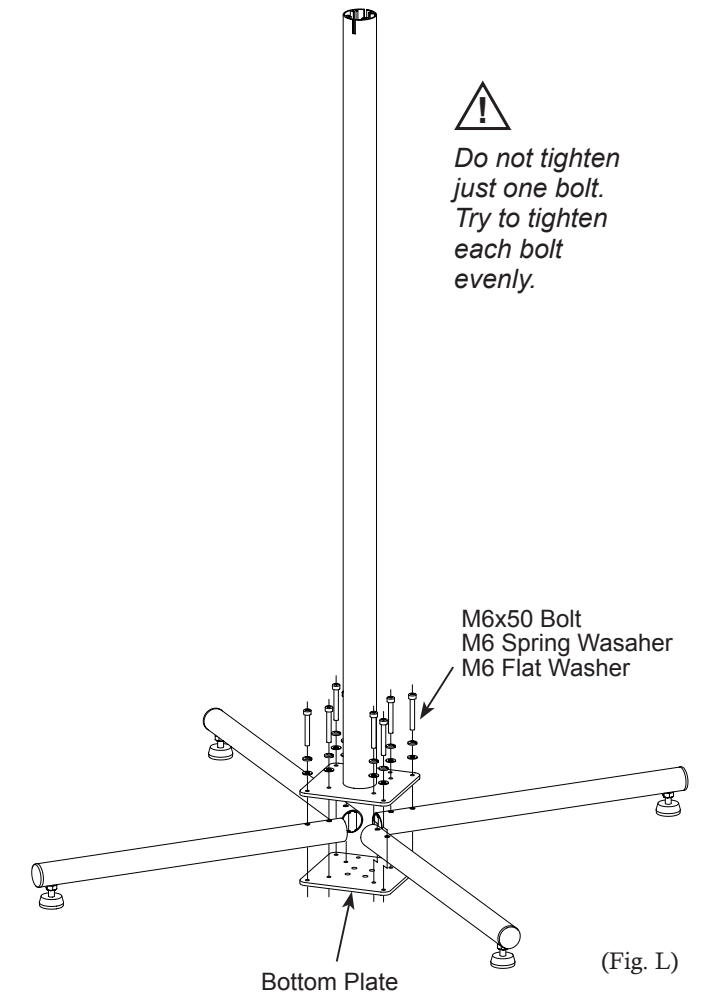
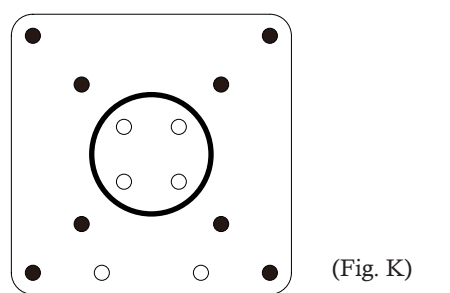

### About Foot Adjusters

The Foot Adjuster works to make this rack standing stable and correctly vertical without any backlash.

Screw the Foot Adjuster to adjust the length. Once the length is fixed, tighten the Lock Nut toward the Leg fully and fix the position by the 13mm spanner.

## Join the Pillars

The pillars on P-600AL-6S are separated, not a single piece. Both pillars have same diameter, and the Pillar Joint fastens the pillars. The Pillar Joint has already been installed on the Upper Pillar. You insert it into the Lower Pillar, then tighten the clamps to fix.

- 1** At first, loosen the clamp on the Lower Pillar by M5 hex wrench. (see Fig. M)
- 2** Insert the Pillar Joint into the Lower Pillar.
- 3** While holding both pillars are tightly attached, tighten the clamp firmly. (tightening torque: **8 N.m**)



**Regularly check if the clamp bolts are securely tightened. If these bolts become loose, the pillar could come apart and fall down.**



**If too much torque is applied when tightening, the bolt may become deformed. If the clamp ends touch each other, then the clamp is no longer safe to use and needs to be replaced.**

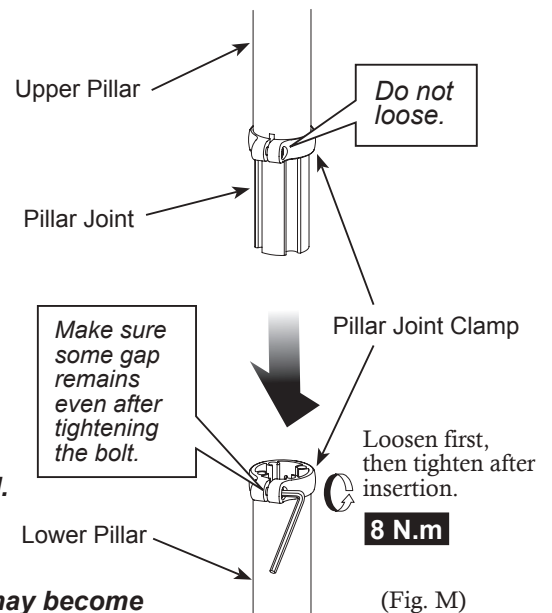

## Install Top & Bottom Hooks

<Top Hook for front wheel>

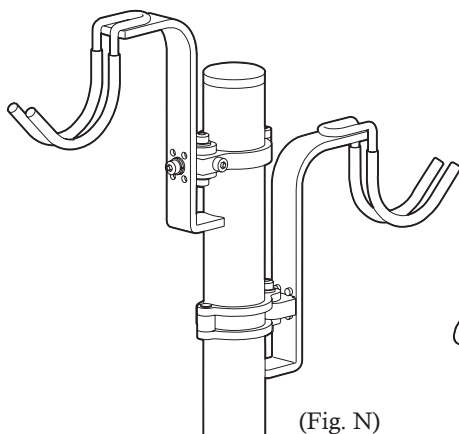

<Bottom Hook for rear wheel>

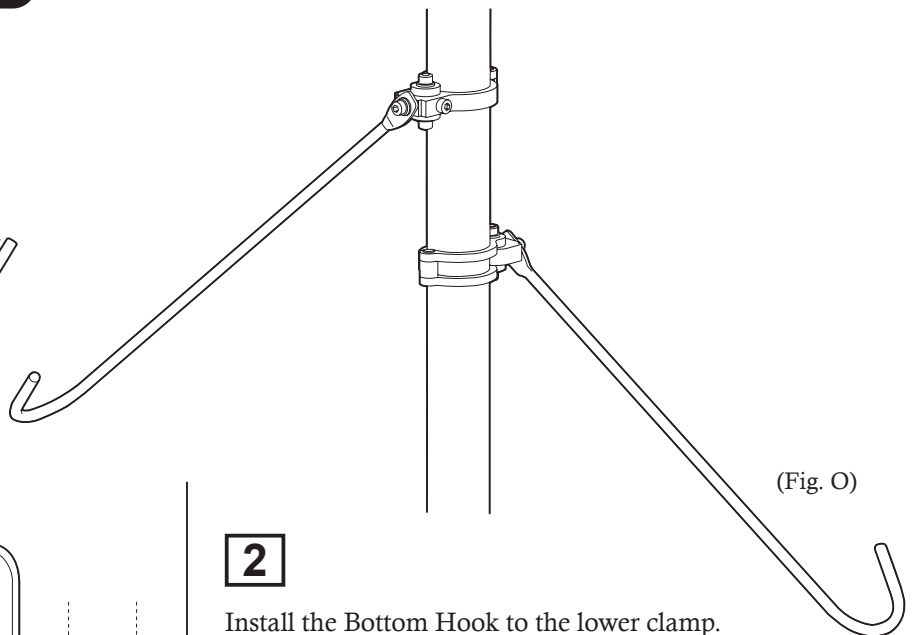

**1**

Install the Top Hook to the upper clamp. Make sure the clamp is placed between the four projections on the hook.

Screw the bolt using your finger at least in the first 3–4 rotations. After confirming the bolts thread correctly, use the tool to tighten.

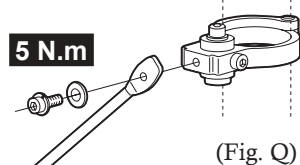
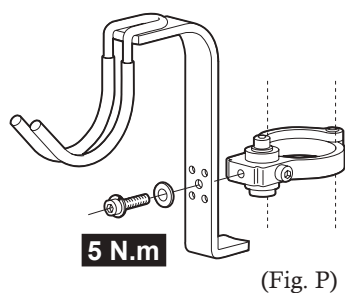

**2**

Install the Bottom Hook to the lower clamp. You don't have to fix the Bottom Hook. Adjust the tightening as the hook won't come down by its own weight.



**The distance between the Top Hooks is usually narrower than the handlebar width, so the bikes hanging from the hook on P-600 must be positioned that both bikes are not in the same level, but one bike is a little lower than other. At this time, make sure that the rear tire on the lower bike does NOT touch the floor. It will disturb the bike stability significantly. Set the bike height that the rear tire is OFF the floor.**



**It is possible on any threaded mechanism that the bolt can be forced on at an angle. If this happens the bolt usually stops in one turn. If you feel the bolt is threading incorrectly do not continue or doing so will cause damage to the thread, possibly destroying it. Properly threaded bolts will turn easily so using your fingers to get the bolt started insures you'll know if the bolt is installed correctly.**



**3**

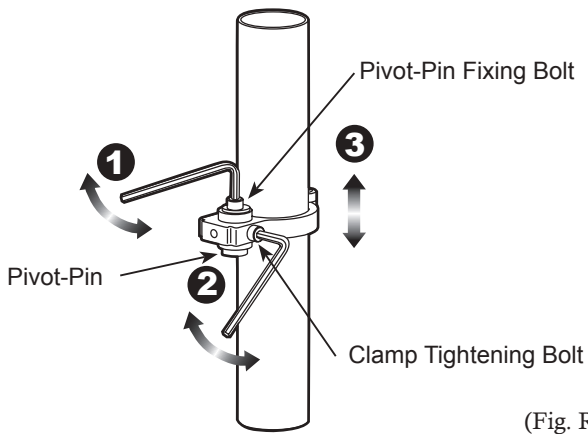

(Fig. R)

Move the clamp with hook to your desired position.

The hook can be positioned anywhere you want, but you must place it to just beside the pillar when you choose K-style leg.

To move the clamp, loosen ① clamp tightening bolt and ② pivot-pin fixing bolt together with M5 hex wrench, then ③ slide the clamp along the pillar.



*The clamp may not move if you loosen the side bolt only. You should loosen both bolts.*



*Be sure the clamp touches the pillar directly. If you don't loosen the bolt enough, it may cause scratching.*



*When you set the legs in K-style, you must place the hooks just beside the pillar, otherwise the stand may tip over due to improper balance.*

Adjust the bottom hooks clamp height as the bike becomes vertical when hooking the rear tire in the deepest position.

After moving, firmly tighten both ① and ② bolts.

### About Top Hook



*The Top Hook is covered by black Vinyl tube. This works to protect the wheel rim surface from scratching problem while hanging from the hook.*

*Please note, this Vinyl tube may possibly stick to a rim/ wheel decal or carbon wheels, especially. This could be caused by room temperature or extended storage time.*

*This issue can be avoided by removing the Vinyl tube and using a single sided tape in place of the Vinyl tube. Minoura is not responsible to any damage the Vinyl tube may cause to your wheels or bicycle.*

### How To Reinstall Clamp Band

The clamp bands come pre-installed and they should not need to be removed. However, there may come a time when adding options to your P-600AL-6S that you will need to remove them.

Install the clamp properly as instructed below.

Failure to do so may cause parts damage or may cause the bike to come off the stand..

**1**

Wind the clamp arms around the Pillar.

The following description is set as the single side arm is on YOUR right, and the double side arm is on YOUR left.

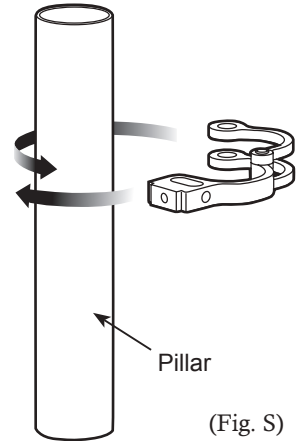

(Fig. S)

**2**

Put the Pivot-Pin through all 3 holes on the clamp band from bottom side, and screw the Pivot-Pin Fixing Bolt with a flat washer temporarily.



*Make sure to insert the Pivot-Pin from the bottom. If you don't, you will not be able to tighten the bolt using a hex wrench.*



*Do not tighten the Pivot-Pin Fixing Bolt firmly yet. The next job will become difficult.*

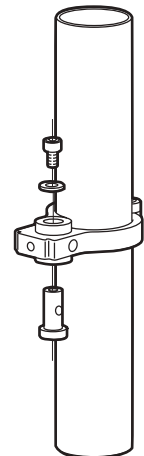

(Fig. T)

**3**

Turn the Pivot-Pin to align the thread hole to the side hole on the clamp band.

Screw the Clamp Tightening Bolt into the Pivot-Pin.

To fix the clamp band firmly, tighten the Clamp Side Pin first then tighten the Pivot-Pin Fixing Bolt later.

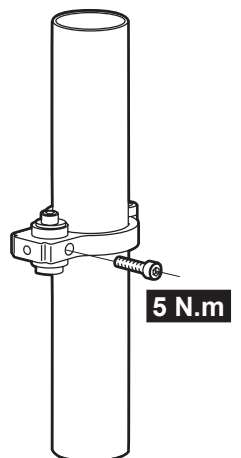

(Fig. U)