

## Components

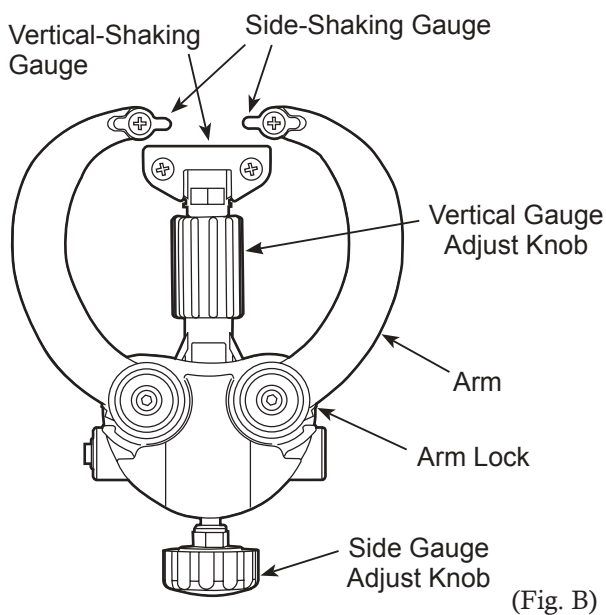

When you need to order replacement parts, refer the schematics on the last page then order it with the correct part number or part name.

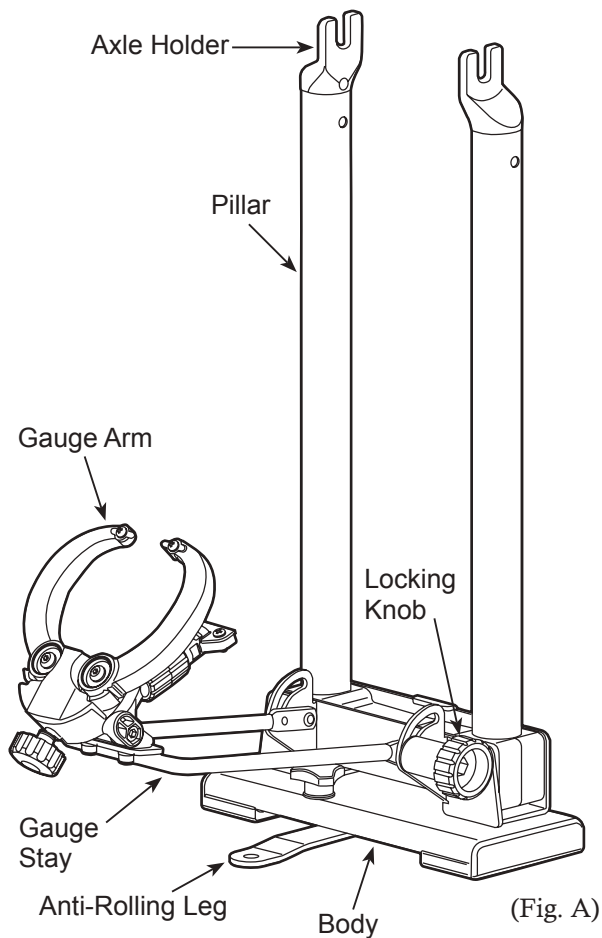

## Important Notes

- **Turing wheels is done at your risk. Minoura is not liable for any damage that may be caused by improper use of the stand. Wrong wheel adjustment may cause poor brake performance or spoil bike stability. You can use FT-1 only when you accept this caution. And Minoura will understand you accept this caution when you start using FT-1.**
- **Only use the FT-1 to true bicycle wheels and for no other purpose.**
- **FT-1 will work with 9mm quick release skewers and fixed nut axels, too. 15mm / 20mm thru axle can be used when using optional adapters. Any other size thru axle will not fit to FT-1.**
- **Both pillars are constructed to move together. This helps to readjust the gauge position when changing to a different hub. This is NOT an "Auto-Centering" feature. You must use a wheel dishing tool to check wheel symmetry.**
- **When mounting a wide hub and tightening the skewer, the wheel may not seat correctly because the axle holders are angled. Push down the wheel to set it in the deepest position on the Axle Holder when you tighten the quick release skewer.**
- **You will use only one Side Shaking Gauge when checking the wheel. Widely open and lock the gauge arm which you don't use.**

## Side Shaking Gauge

Side Shaking Gauge is for checking the horizontal movement of the wheel.

The purpose of this job is making the distance (gap) between the rim surface and the brake shoe equal on all around the wheel in order to expect greater brake performance.

This job can be accomplished with the tire on or off the wheel.

Set the wheel on the stand and position the tip of the Side Shaking Gauge 1 - 2mm away from the rim surface (do not touch). (see Fig. C)

Rotate the wheel slowly (do not spin fast) and look at the clearance between the rim surface and the gauge tip. The gap will change vary and when the rotating wheel comes in contact with the gauge, you will hear a scratching sound.

Turn the nipples to make this gap equal on all around the wheel.

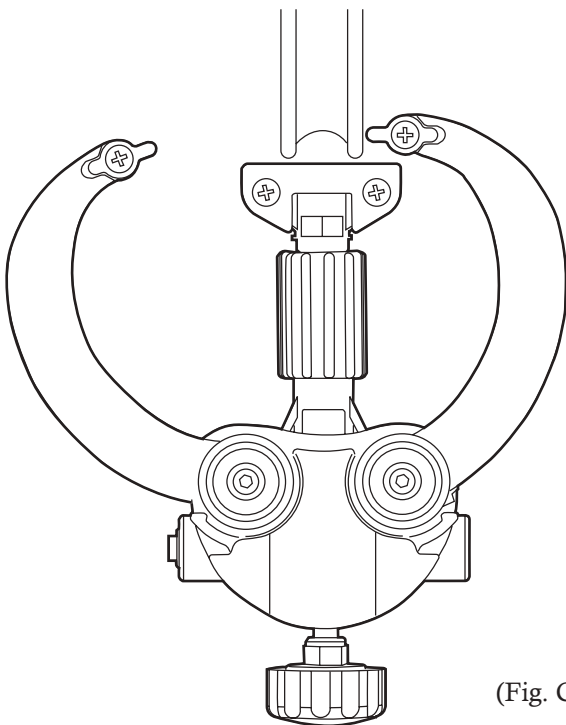

In case that you see the wheel from right hand side to true the wheel.

On side shaking truing job, you use either right or left side gauge. You will not use both gauges at once.

Depends on your dominant eye, use the gauge arm on your favorite side.

Fig.C shows then case you are dexitral.

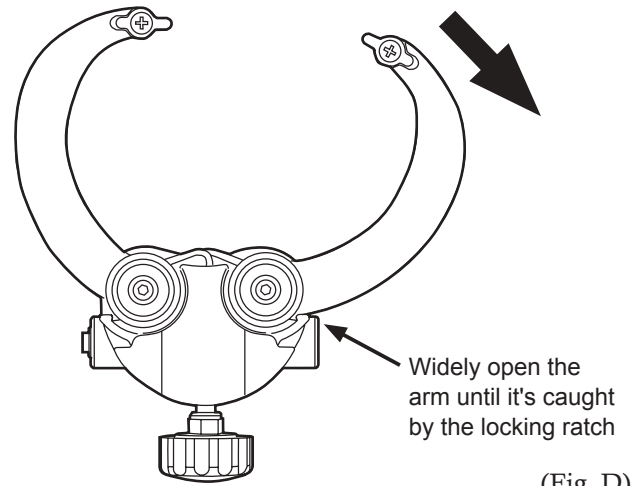

The side shaking gauge arm can be locked in widely open position.

Hold the arm and move open. When the arm is caught by the locking ratch, you will feel click. This is the locking position. (see Fig. D)

Do not force to open more.

To close the arm, push it inward.

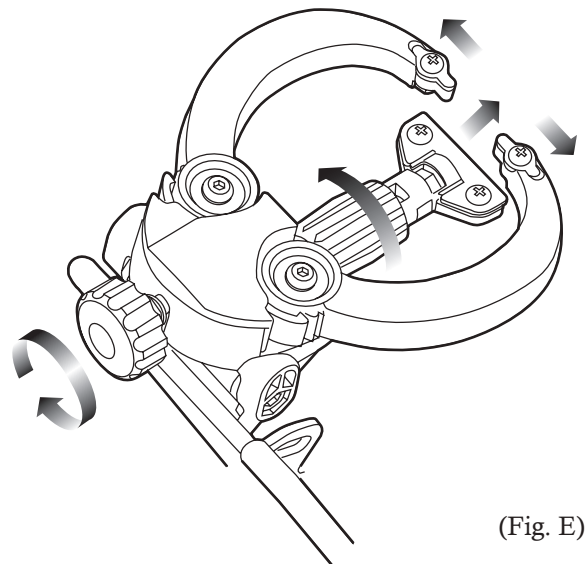

Turn the Side Gauge Adjust Knob, then both arms move together. If the arm is in locked position, it won't move even you turn the knob.

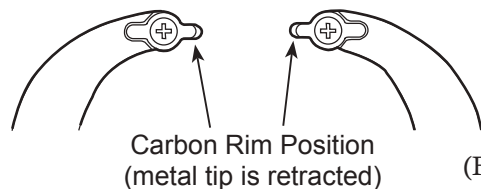
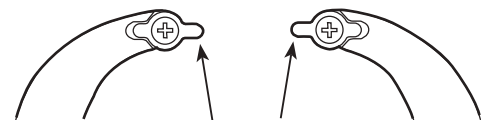

Turing wheels means the gauge has to touch the rim and this may cause some light scratching.

If you use an expensive carbon rim and you don't want to scratch it, flip the metal piece on the Side Shaking Gauge. In this position, only the plastic arm body contacts the rim and it won't damage the rim. (see Fig. F)

The contact sound between the tool and rim will become fainter and more difficult to hear.

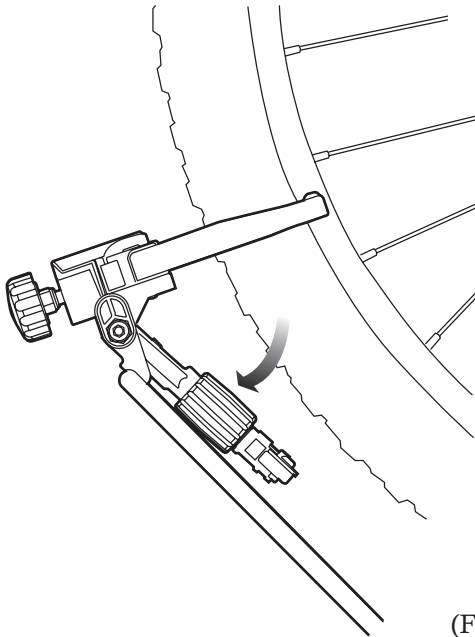

(Fig. G)

The angle of the gauge arm should be set as deep as possible. (see Fig. G)

If the Vertical Shaking Gauge touch the tire, fold it down or remove the tire.

## Vertical Shaking Gauge

Vertical Shaking Gauge is for checking the vertical movement of the wheel.

The purpose of this job is making the wheel concentric circle to make the riding smoother. You must remove the tire from the wheel when doing this job.

Raise up the Vertical Shaking Gauge Arm (and extend the arm length by turning the center barrel type knob if necessary) to position the tip 1 - 2mm away from the rim edge (do not touch). (see Fig. H)

Rotate the wheel slowly (do not spin fast) and look at the clearance between the rim edge and the gauge tip. The gap will change vary and when

the rotating wheel comes in contact with the gauge, you will hear a scratching sound.

Turn the nipples to make this gap equal on all around the wheel.

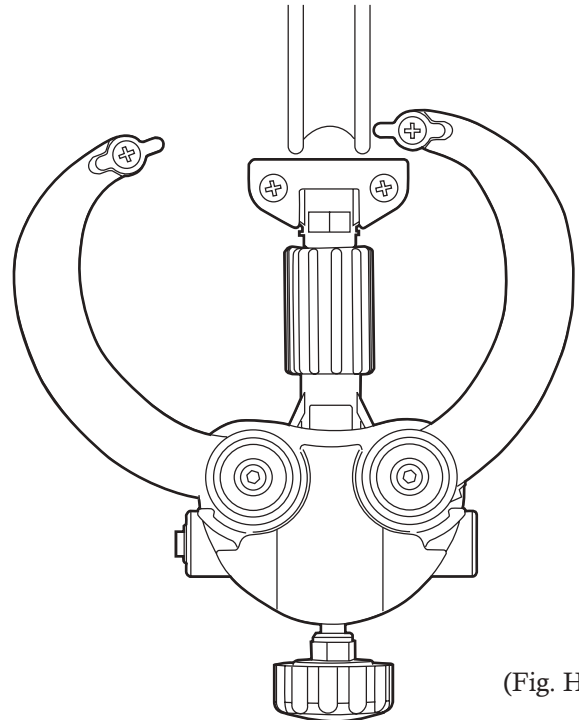

(Fig. H)

The gauge arm angle against the rim should be as deeply as possible.

Turing wheels means the gauge has to touch the rim and this may cause some light scratching.

If you use an expensive carbon rim and you don't want to scratch it, remove the metal bracket from the Vertical Shaking Gauge and only the plastic part contacts the rim.

Be sure the contacting sound will have to become very small and difficult to listen.



***If the Vertical Shaing Gauge has been twisted by some reason, it will contact only either edge of the rim.***

***Even in this condition, you can continue the wheel truing job without any problem, but if you want to have the gauge contacts both edges at once, twist the gauge.***

## How To Fold Down

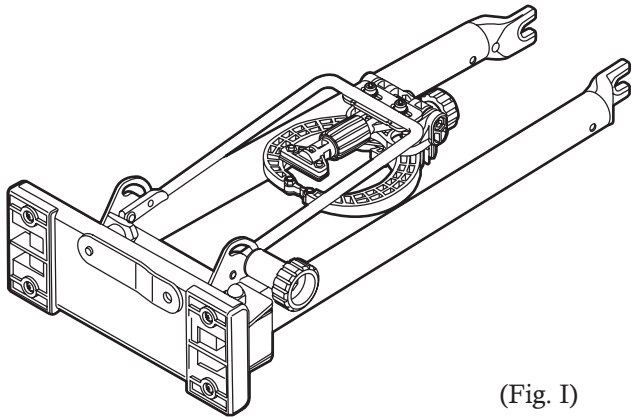

(Fig. 1)

FT-1 is completely foldable for easier transportation and compact storage.

To fold down, follow the steps;

1. Shut the Side Gauge as narrow as possible.  
(if you don't want to change the gauge clearance, you can leave it in current position)
2. Close the pillars by pushing inward from both sides at same time.
3. Loosen the Lock Knob.
4. Fold the gauges ***downward*** and push toward the Pillars.
5. Tighten the Lock Knob.
6. Turn the Anti-Rolling Leg to store under the body, then tighten the triangle head knob bolt.



***Be careful not to pinch your fingers between the body and stay.***



***Do not try to store the gauge between the pillars.  
If strong sideward shock is applied, the plastic gauges should be broken.***

## About Anti-Rolling Leg

You will see a retractable leg underneath the FT-1 body. This is for preventing the rolling down problem due to the worse balance when a wheel sits on the stand.

The hole on the leg is fixing FT-1 on your workbench with a screw.

To retract the leg, loosen the triangle knob bolt, flip out the leg, then tighten the knob again.

## Pillars

To open or close the pillars, hold them with both hands and move at once.

If you move just one side pillar or push or pull the pillar to different direction, your FT-1 should be deformed.

This will cause a serious problem that FT-1 no longer holds the wheel in proper angle and you cannot expect correct result from wheel truing job.

## Steps of Wheel Truing Job

Usually, wheel truing job is done with the following steps.

Different job step may force you to re-adjust the point you already done and it will take time longer.

You need to think about the jobs totally. You should not focus on just one point.

### 1. Vertical shaking adjustment



### 2. Side shaking adjustment



### 3. Wheel symmetry check & Off-set adjustment



### 4. Spoke tension adjustment

You need to have a long fuse. Wheel truing job is quite difficult for beginners and you should not expect right result from just one action.

If you feel that you cannot finish it by yourself, it's highly recommended to ask to a professional or well-skilled mechanics.

Some shaking on the wheel is not problem for your daily use, but be careful about the spoke tension. Bad adjustment will cause serious accident.

## About Offset Wheel Setting

At first, you should understand that you should fix the vertical movement prior to the horizontal movement, especially on the rear wheel because of its unique wheel system named **"Offset"**.

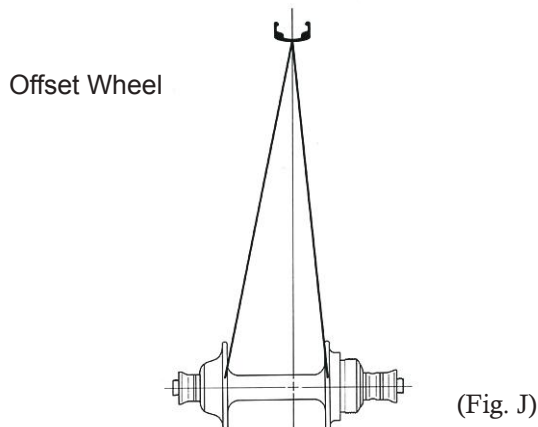

Tensioning the front wheel is much easier than the rear. Rear wheel tensioning requires Offset Tensioning.

The rear wheel has a different spoke angle pattern when looking at it from behind. (see Fig. J) A rear hub is not symmetrical to the wheel. Flanges can be far from center. Because the rear hub must have extra space for the set of transmission gears, you will need to true using Offset Tensioning.

If offset wheel, the torque works mostly only to the right side (gear side) spokes. Because right side spokes should be assembled more vertically than left side.

Understand that right side spoke tension is more important than left side spoke's one in this offset assembling.

Well adjusted right side spokes can keep your wheel stable in the future. Left side spoke tension is just a help.

The nipple should not be loosened at any time. Nipples are made from softer alloys or brass and are prone to stripping easily.



**You must use a correct spoke wrench which fits the nipples perfectly, especially when you use light alloy nipples on your wheel. If you use wrong size one, the nipple will become round easily and you cannot continue your work any more.**

## How To Fix Vertical Movement

The vertical movement within 3 mm may not cause any troubles. But if you want to be it as zero as possible for smoother ride, you should try the following process again and again.

Be sure, in this case, you should tighten both side of the nipples equally.

**1.**  
You set the wheel on the FT-1 and see the Vertical Gauge.  
Put the tip of the Vertical Gauge close to the surface of the rim.

**2.**  
Rotate the wheel slowly, and check the vertical movement. Do not spin fast.

**3.**  
Attach tapes to two spokes; one is in the beginning and another one is in the ending of vertical movement.

**4.**  
Make three (3) groups of spokes between your tape markers as below;

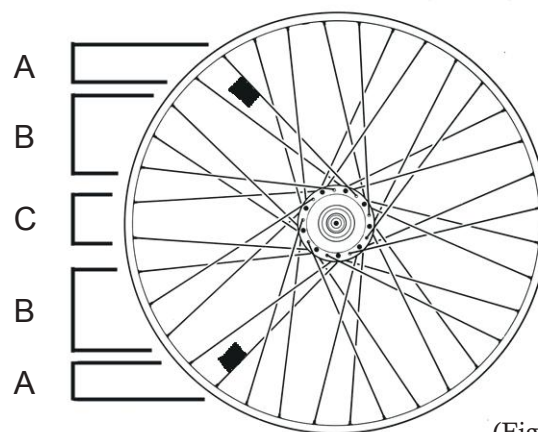

**Group-A:** 3 or less spokes in the beginning and in the ending of vertical movement.

**Group-B:** 3 or less spokes between Group-A, except for the center spoke.

**Group-C:** The center 1 or 2 between the tapes.

**5.**  
If the rim moves to outward, tighten both side nipples.

If the rim shakes inward, do NOT try to loosen the nipples. Tighten both far side nipples. This is because the nipples are made of soft material, so its thread can be broken easily by loosening.

## 6.

Tighten the spokes as below;

- Group-A nipples = about 1/8 turns
- Group-B nipples = about 1/4 turns
- Group-C nipples = about 1/2 turns

Then check the vertical movement again with rotating the wheel slowly.

If the wheel moves yet, continue the process again.



***If you hear a strange sound or see narrow metal "lines" or residue, your nipple will fail soon.***

***Do NOT apply any lubricant to quiet the sound. Put a new nipple on immediately.***



***Do NOT tighten the spoke more than 1/2 turns at one time. Wheel truing must be done step by step. Otherwise, you will lose the spoke tension balance completely.***

## How To Fix Horizontal Movement

The horizontal movement within 2 mm may not cause any troubles. But if you want to be it as zero as possible for smoother ride, you should try the following process again and again.

### 1.

You set the wheel on the FT-1 and see the Side Gauges.

Put the tips of them close to the surface of the rim side wall. Do not make them touch the rim.

### 2.

Rotate the wheel slowly, and check the horizontal movement. Do not spin fast.

### 3.

Attach tapes to two spokes; one is in the beginning and one is in the ending of horizontal movement.

### 4.

Make three (3) groups of spokes between your tape markers as below;

**Group-A:** 3 or less spokes in the beginning and in the ending of horizontal movement.

**Group-B:** 3 or less spokes between Group-A, except for the center spoke.

**Group-C:** The center 1 or 2 between the tapes.

## 5.

If the rim moves to right, tighten the left side nipples. Do NOT loosen the right side nipples.

This is because the nipples are made of soft material, so its thread can be broken easily by loosening.

## 6.

Tighten the spokes as below;

- Group-A nipples = about 1/8 turns
- Group-B nipples = about 1/4 turns
- Group-C nipples = about 1/2 turns

Then check the horizontal movement again with rotating the wheel slowly.

If the wheel moves yet, continue the process again.



***If you hear a strange sound or see metal "lines" or residue, your nipple will fail soon.***

***Do NOT apply any lubricant to quiet the sound. Put a new nipple on immediately.***



***Do NOT tighten the spoke more than 1/2 turns at one time. Wheel truing must be done step by step. Otherwise, you will lose the spoke tension balance completely.***

There are several ways to true the bike wheel, and there are many spoke crossing patterns available depends on the purpose on wheel. Above is just one example and you don't have to follow our way. You should refer a bike maintenance guidebook or ask to well-educated mechanics to learn more effective techniques.

## Limited Warranty Policy

Minoura offers -year limited warranty on this product under the following conditions;

1. Only the original user who purchased this FT-1 in brand-new and unopened condition at an authorized Minoura dealer, authorized internet retailer or authorized mail order house (hereafter "Original User") is covered under the Minoura Warranty Service Program (hereafter "Warranty Service").
2. Any used or new FT-1, either purchased or given through a shop, internet auction site or person-to-person will NOT be covered under Warranty Service, except under special circumstances to be determined by Minoura.
3. Original User must keep the original sales receipt and must present a photocopy of the receipt together with a claim report to obtain Warranty Service.
4. The warranty period shall start from the date of purchase. If the receipt is not presented, Minoura reserves the right to extend or deny Warranty Service.
5. All warranties will be void if the FT-1 is damaged due to user's abuse, disassembly, unauthorized alteration or modification, or used in any way not intended as described in the instructions manual.
6. Only issues caused by manufacturer's defects will be covered to all users at Minoura's expense. The period expires in a maximum of 7 years after the last production.
7. Minoura may offer paid service for in or out of warranty products that may include, but is not limited to, repair, replacement and shipping expenses.

For more detailed information, refer both the attached "MINOURA LIMITED WARRANTY POLICY" card and our web site (<http://www.minourausa.com>).

Web can offer you the latest and more correct information.

## For More Information...

*\* When you need help, please contact the shop first where you purchased FT-1.*

### **MINOURA Japan Headquarters** **(for ALL customers)**

1197-1 Godo, Anpachi, Gifu 503-2305 Japan  
Phone: +81-584-27-3131  
Fax: +81-584-27-7505  
Email: [minoura@minoura.jp](mailto:minoura@minoura.jp)  
URL: [www.minourausa.com](http://www.minourausa.com)

### **MINOURA North America** **(for U.S. residents only)**

California, U.S.A.  
Phone: 1-510-538-8599  
Fax: 1-510-538-5899  
Email: [support@minourausa.com](mailto:support@minourausa.com)

*\*\* For countries not listed, please see our web site at [www.minoura.jp](http://www.minoura.jp) to find the Minoura distributor in your country and contact them for service.*

**Made in Japan**

# FT-1 Schematics

# MINOURN

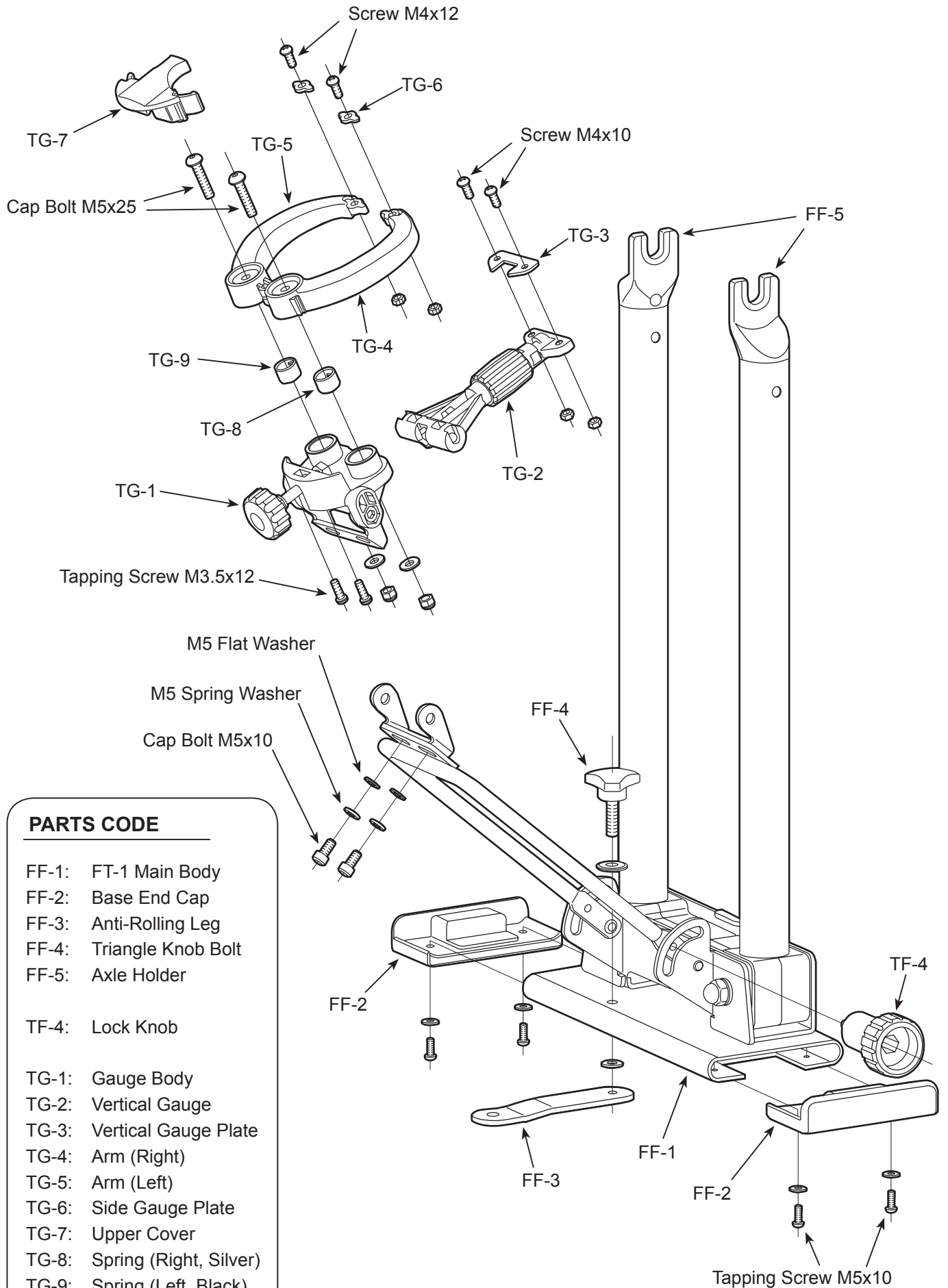

## PARTS CODE

- FF-1: FT-1 Main Body
- FF-2: Base End Cap
- FF-3: Anti-Rolling Leg
- FF-4: Triangle Knob Bolt
- FF-5: Axle Holder
  
- TF-4: Lock Knob
  
- TG-1: Gauge Body
- TG-2: Vertical Gauge
- TG-3: Vertical Gauge Plate
- TG-4: Arm (Right)
- TG-5: Arm (Left)
- TG-6: Side Gauge Plate
- TG-7: Upper Cover
- TG-8: Spring (Right, Silver)
- TG-9: Spring (Left, Black)